



250 Staunton Turnpike, Parkersburg, WV 26104

400 SERIES Vinyl Horizontal Sliding Window w/ Nailing Fin "NON-IMPACT"

GENERAL NOTES

1. This product has been evaluated and is in compliance with the 8th Edition (2023) Florida Building Code (FBC) structural requirements excluding the "High Velocity Hurricane Zone" (HVHZ).
2. Product anchors shall be as listed and spaced as shown on details. Anchor embedment to base material shall be beyond wall dressing or stucco.
3. When used in areas requiring wind borne debris protection this product is required to be protected with an impact resistant covering that complies with FBC Sections 1609.1.2 & R301.2.1.2.
4. For 2x stud framing construction, anchoring of these units shall be the same as that shown for 2x buck masonry construction. Increase anchor length to account for exterior sheathing.
5. Site conditions that deviate from the details of this drawing require further engineering analysis by a licensed engineer or registered architect.

TABLE OF CONTENTS	
SHEET#	DESCRIPTION
1	Typical elevations, design pressures and general notes
2	Horizontal and vertical cross sections
3	Buck and frame anchoring
4	Bill of materials, components & glazing details

L7 Shind

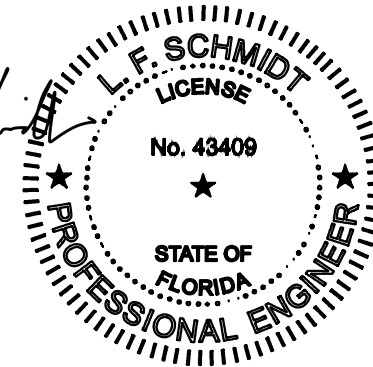

This item has been digitally signed and sealed by L. F. Schmidt, P.E. on the date adjacent to the seal. Printed copies of this document are not considered signed and sealed and the signature must be verified on any electronic copies.

THIS PRODUCT APPROVAL IS VALID ONLY FOR THE STATE OF FLORIDA

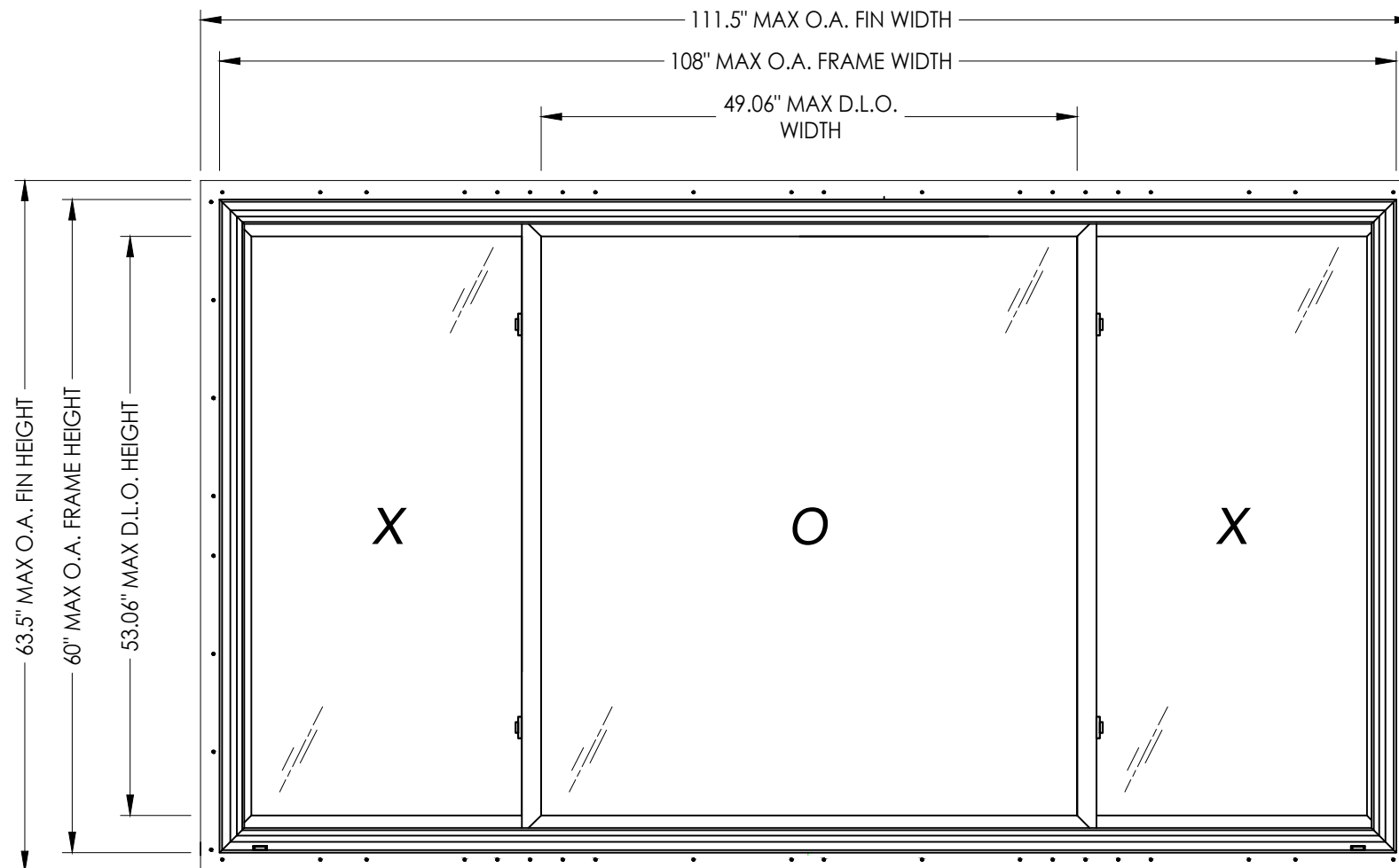

MAX. FIN DIMENSION	MAX. FRAME DIMENSION	MAX. D.L.O. DIMENSION	GLASS TYPE	DESIGN PRESSURE (PSF)	
				POSITIVE	NEGATIVE
111.5" X 63.5"	108.0" X 60.0"	49.06" X 53.06"	G1	+20.0	-20.0
99.5" X 51.5"	96.0" X 48.0"	43.06" X 41.06"	G1	+40.0	-40.0

Documents Prepared By:
Lyndon F. Schmidt
P.E. No. 43409

RW BUILDING CONSULTANTS, INC.
P.O. Box 230, Valrico, FL 33595
Phone No.: 813.659.9197
FBPE Registry No. 9813

PRODUCT: 400 SERIES
1/4-1/2-1/4
PART OR ASSEMBLY:
TYPICAL ELEVATION, DESIGN PRESSURES & GENERAL NOTES

NO.	DATE	BY	REVISIONS
4	7/06/23	LFS	UPDATE TO 8TH ED. (2023) FBC
3	7/06/20	LFS	UPDATE TO 7TH ED. (2020) FBC
2	6/01/17	LFS	UPDATE TO 6TH ED. (2017) FBC
1	1/28/15	JK	UPDATE TO 5TH ED. (2014) FBC

DATE: 10/4/13
SCALE: N.T.S.
DWG. BY: JK
CHK. BY: LFS
DRAWING NO.: FL-16092.13
SHEET 1 OF 4

G:\2023 FBC DRAWINGS\Wincore Window Company\FL-16092 R9\FL-16092.12-14.dwg

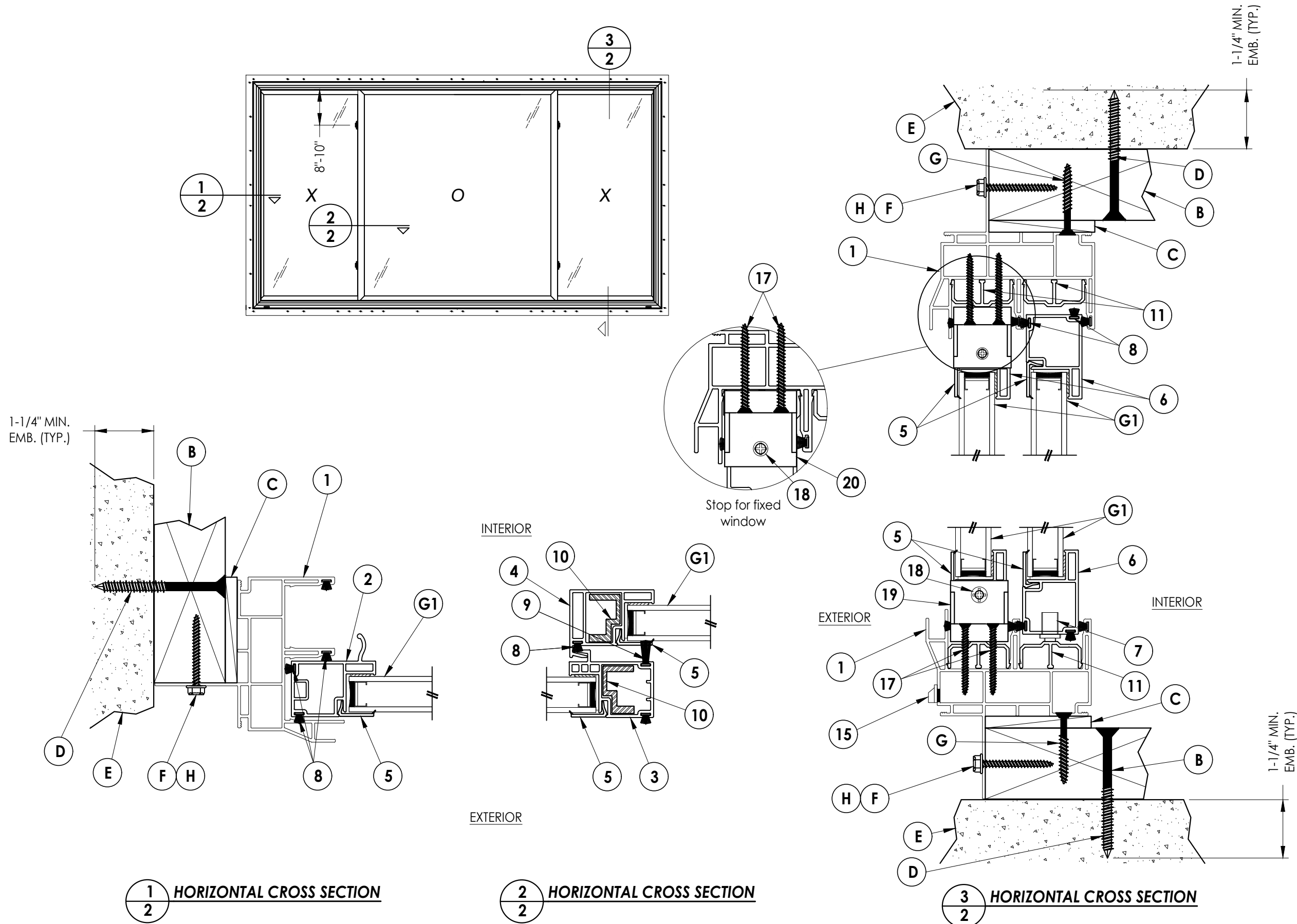

1
2 HORIZONTAL CROSS SECTION

2
2 HORIZONTAL CROSS SECTION

3
2 HORIZONTAL CROSS SECTION

Documents Prepared By: Lyndon F. Schmidt P.E. No. 43409		BUILDING CONSULTANTS, INC. P.O. Box 230, Valrico, FL 33595 Phone No.: 813.659.9197 FBPE Registry No. 9813	
PRODUCT: 400 SERIES 1/4-1/2-1/4		PART OR ASSEMBLY: HORIZONTAL AND VERTICAL CROSS SECTIONS	
4	7/06/23	UPDATE TO 8TH ED. (2023)	FBC LFS
3	7/06/20	UPDATE TO 7TH ED. (2020)	FBC LFS
2	6/01/17	UPDATE TO 6TH ED. (2017)	FBC LFS
1	1/28/15	UPDATE TO 5TH ED. (2014)	FBC JK
NO.	DATE		BY
			REVISIONS
DATE: 10/4/13			
SCALE: N.T.S.			
DWG. BY: JK			
CHK. BY: LFS			
DRAWING NO.: FL-16092.13			
SHEET 2 OF 4			

© 2013 R.W. BUILDING CONSULTANTS INC.

G:\2023 FBC DRAWINGS\Wincore Window Company\FL-16092 R9\FL-16092.12-14.dwg

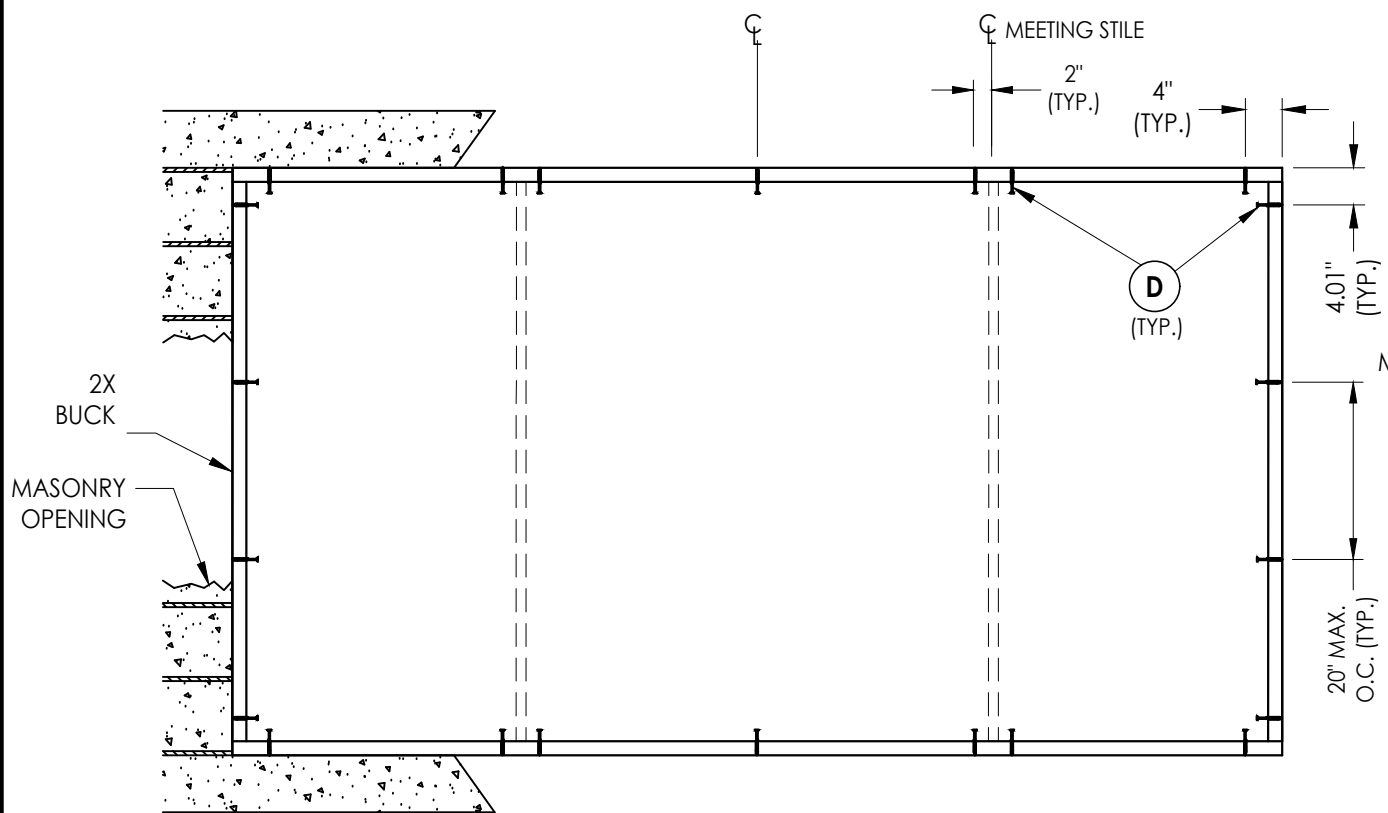

BUCK ANCHORING

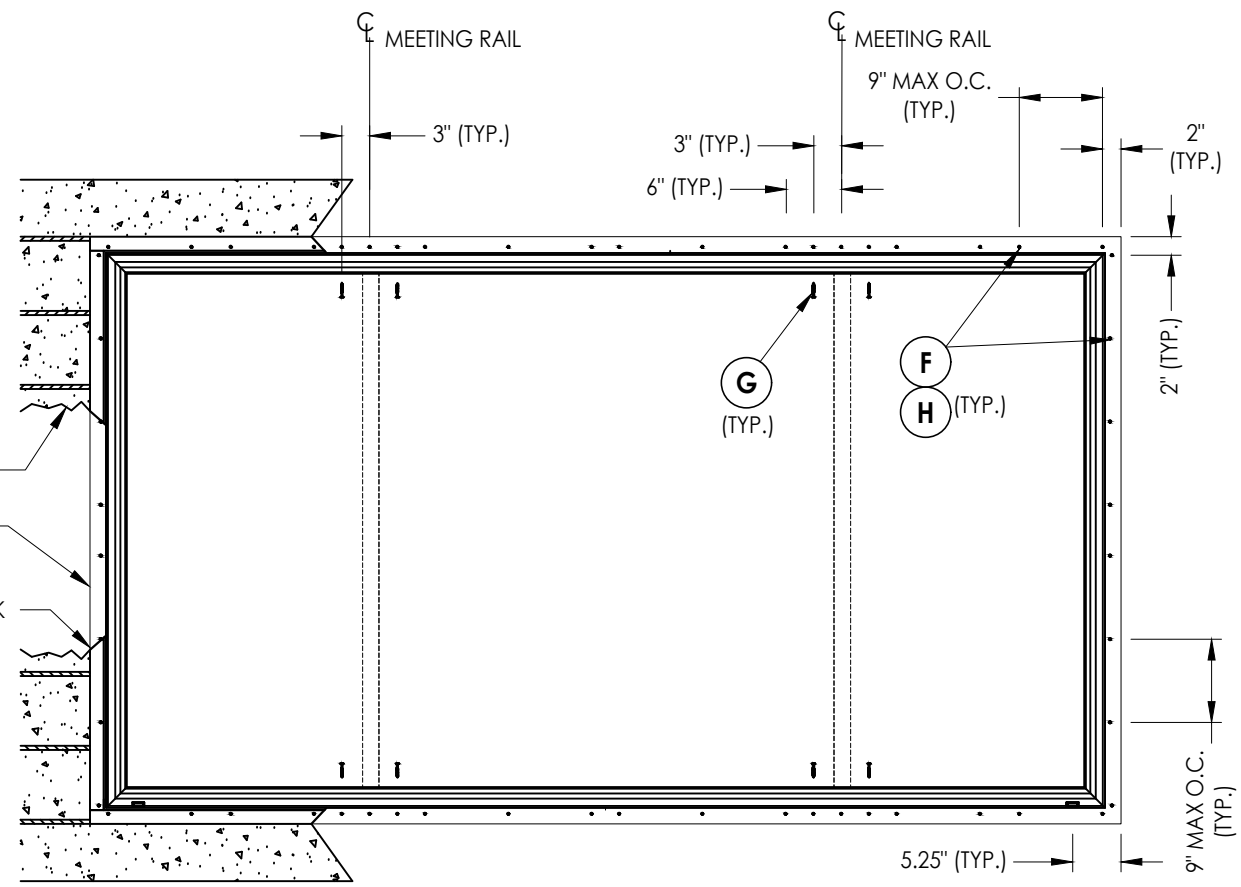

FRAME ANCHORING

CONCRETE ANCHOR NOTES:

1. Concrete anchor locations at the corners may be adjusted to maintain the min. edge distance to mortar joints.
2. Concrete anchor locations noted as "MAX. ON CENTER" must be adjusted to maintain the min. edge distance to mortar joints, additional concrete anchors may be required to ensure the "MAX. ON CENTER" dimension are not exceeded.
3. Concrete anchor table:

ANCHOR TYPE	ANCHOR SIZE	MIN. EMBEDMENT	MIN. CLEARANCE TO MASONRY EDGE	MIN. CLEARANCE TO ADJACENT ANCHOR
ITW TAPCON®	1/4"	1-1/4"	2"	4"
ELCO ULTRACON®	1/4"	1-1/4"	1"	4"

WOOD SCREW INSTALLATION NOTES:

1. Maintain a minimum 5/8" edge distance, 1" end distance, & 1" o.c. spacing of wood screws to prevent the splitting of wood.

Documents Prepared By:
Lyndon F. Schmidt
P.E. No. 43409

RW BUILDING CONSULTANTS, INC.
P.O. Box 230, Vairico, FL 33595
Phone No.: 813.659.9197
FBPE Registry No. 9813

PRODUCT: 400 SERIES
1/4-1/2-1/4
PART OR ASSEMBLY:
BUCK AND FRAME ANCHORING

NO.	DATE	BY
4	7/06/23	UPDATE TO 8TH ED. (2023) FBC LFS
3	7/06/20	UPDATE TO 7TH ED. (2020) FBC LFS
2	6/01/17	UPDATE TO 6TH ED. (2017) FBC LFS
1	1/28/15	UPDATE TO 5TH ED. (2014) FBC JK
		BY

DATE: 10/4/13
SCALE: N.T.S.
DWG. BY: JK
CHK. BY: LFS
DRAWING NO.: FL-16092.13
SHEET 3 OF 4

BILL OF MATERIALS

ITEM #	DESCRIPTION	Part #	MATERIAL
A	1X BUCK (SG >= 0.42)	-	WOOD
B	2X BUCK (SG >= 0.42)	-	WOOD
C	1/4" MAX. SHIM SPACE	-	-
D	1/4" X 2-3/4" PFH ELCO OR ITW CONCRETE SCREW	-	STEEL
E	MASONRY - 3,000 PSI MIN. CONCRETE CONFORMING TO ACI 301 OR HOLLOW BLOCK CONFORMING TO ASTM C90	-	CONCRETE
F	#8 X 1-1/2" HWH SMS (1-3/8" EMBEDMENT)	-	STEEL
G	#10 X 1-1/2" PFH WOOD SCREW (1-1/4" EMBEDMENT)	-	STEEL
H	#8 X 1-1/2" PPH SMS (1-3/8" EMBEDMENT)	-	STEEL
1	FRAME*	DS5401E	PVC
2	SLIDER PULL STILE*	SE4647	PVC
3	LOCK STILE*	SE4646	PVC
4	KEEPER STILE*	SE4644	PVC
5	GLAZING BEAD*	22841	PVC
6	SLIDER COMMON RAIL*	SE4645	PVC
7	METAL ROLLERS w/ PLASTIC HOUSING	-	-
8	WEATHERSTRIP (0.230")	-	-
9	WEATHERSTRIP (0.380")	-	-
10	REINFORCEMENT (6063-T6 ALUM)	-	ALUM
11	SILL TRACK*	V777	PVC
15	WEEPHOLE CAP*	WEEP-1288	PVC
17	#8 X 1-1/4" PFH SMS	-	STEEL
18	#8 X 3/4" PFH WOOD SCREW	-	STEEL
19	LOWER FLANKER STOP	2991C	NYLON
20	UPPER FLANKER STOP	2991B	NYLON

* THE APPROVED WHITE RIGID PVC EXTERIOR EXTRUSIONS FOR WINDOWS ARE TO BE PRODUCED BY EXTRUDERS LICENSEES IN "AAMA CERTIFICATION PROGRAMS FOR RIGID PVC EXTRUSIONS".

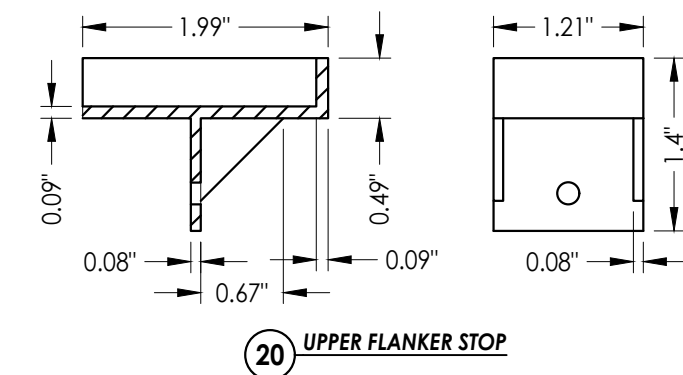
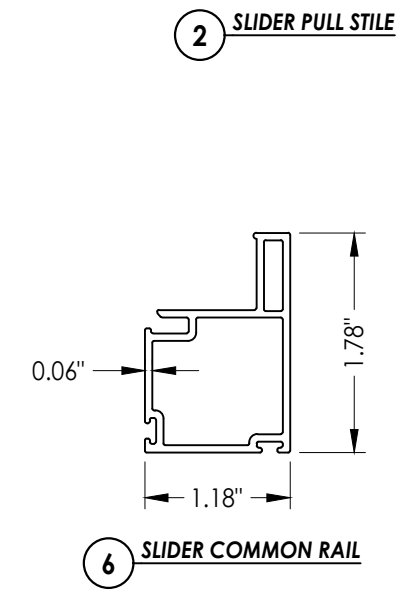
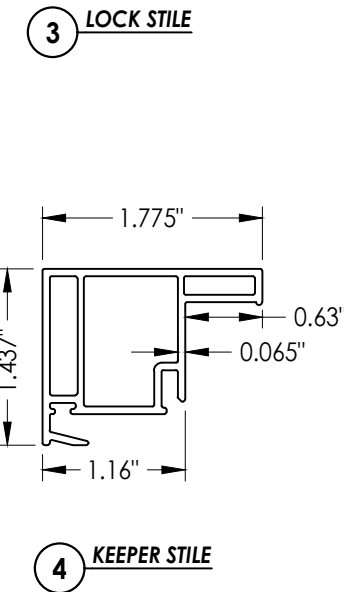
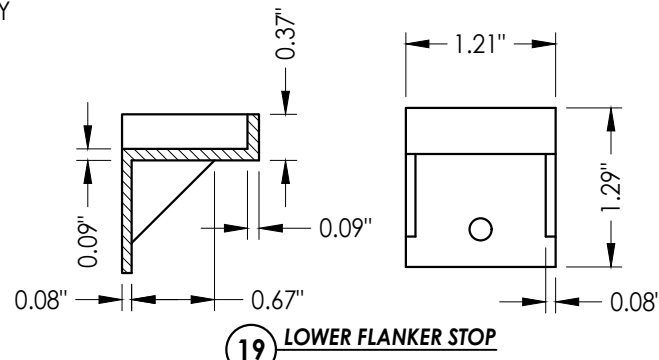
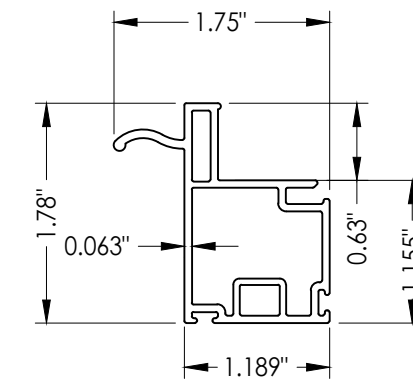
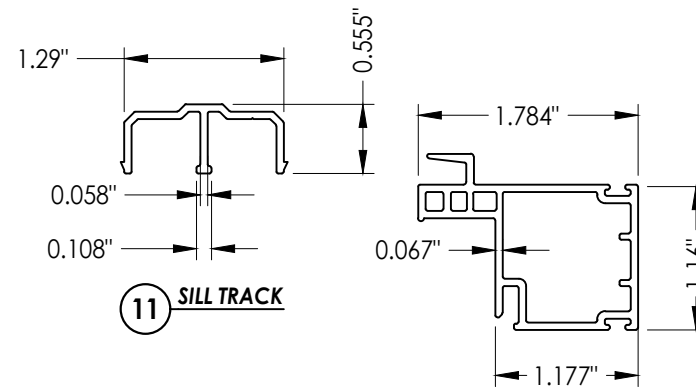
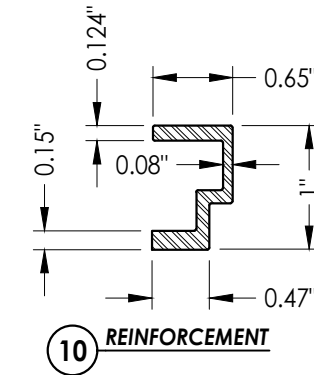
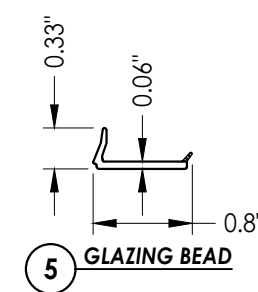
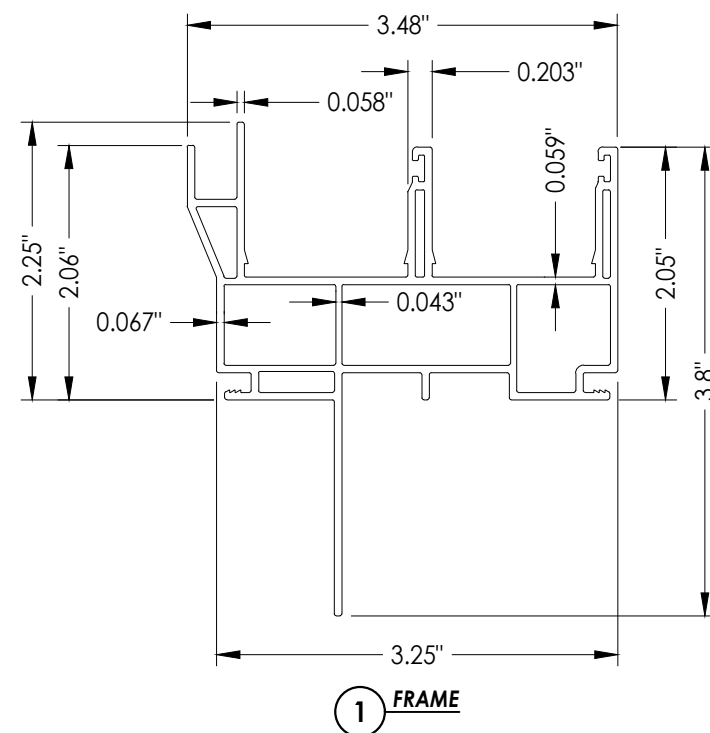
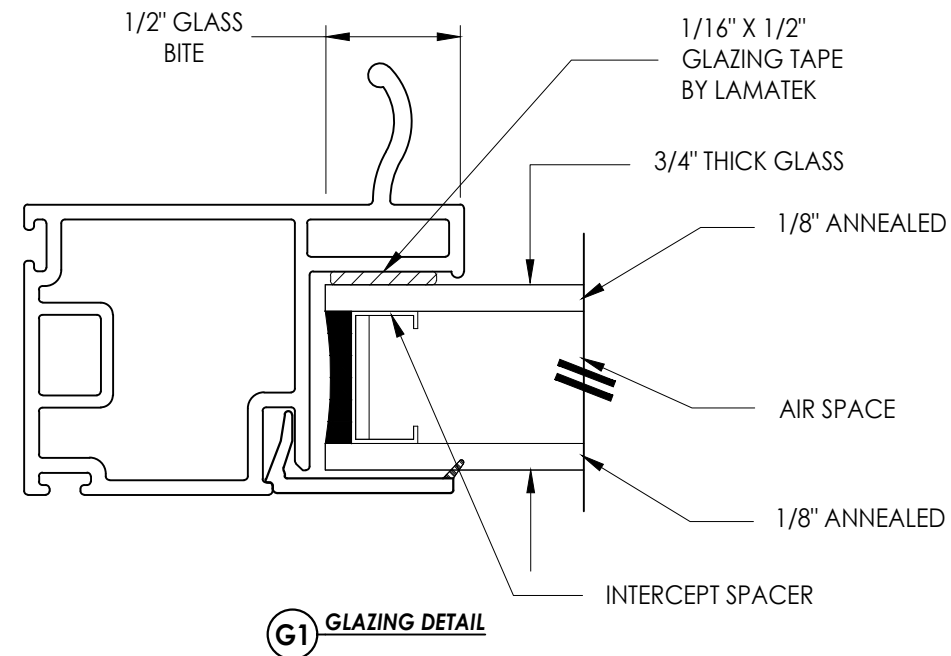

Documents Prepared By:
Lyndon F. Schmidt
P.E. No. 43409

RW BUILDING CONSULTANTS, INC.
P.O. Box 230, Vairico, FL 33595
Phone No.: 813.659.9197
FBPE Registry No. 9813

PRODUCT: 400 SERIES
1/4-1/2-1/4
PART OR ASSEMBLY:
BILL OF MATERIALS, COMPONENTS
& GLAZING DETAILS

NO.	DATE	BY	JK	FBC	LFS	JK	FBC	LFS
4	7/06/23	UPDATE TO 8TH ED. (2023)	FBC	LFS				
3	7/06/20	UPDATE TO 7TH ED. (2020)	FBC	LFS				
2	6/01/17	UPDATE TO 6TH ED. (2017)	FBC	LFS				
1	1/28/15	UPDATE TO 5TH ED. (2014)	FBC	LFS				

DATE: 10/4/13
SCALE: N.T.S.
DWG. BY: JK
CHK. BY: LFS
DRAWING NO.: FL-16092.13
SHEET 4 OF 4